

MALLETTS BAY BOAT CLUB

Colchester, Vermont

Situated on Malletts Bay of Lake Champlain

Founded 1936 - Incorporated 1947



The Malletts Bay Boat Club, Inc. is a not-for-profit, membership-governed club formed to provide facilities and programs to encourage and promote sailing, boating, and other water-related recreational activities on Lake Champlain. Racing, cruising, educational and family-oriented social activities are made available for the enjoyment and benefit of its members of all ages. The perpetuation and enhancement of these facilities and programs are the responsibility of all the membership.

662 West Lakeshore Drive
Colchester, VT

Clubhouse Phone: (802) 658-3959
Website: www.mbbc-vt.org

Mailing Address:
P.O. Box 402
Colchester, Vermont 05446-0402

Table of Contents

| | |
|--|----|
| Table of Contents | 2 |
| Club Officers for 2008 | 2 |
| Club Afterguard | 2 |
| MBBC Racing Program | 3 |
| Notice of Regatta and Sailing Instructions | 8 |
| Races for One-Design Classes | 13 |
| PHRF Series..... | 16 |
| Past Winners of Awards & Races | 28 |
| How Does The Starting System Work? | 40 |
| Mooring Grid | 41 |

Club Officers for 2008

Master – Bill Rogers
Master's Mate – Linda Sheridan
Yeoman - Charly Dickerson

Club Afterguard

Heather Ambrose - '08
Jim Carroll - '08
Luis Gonzalez - '08
Linda Sheridan - '08

Wendelyn Duquette - '09
Geoff Halsted - '09
Rick Ritter - '09
Kay Tran - '09

Alan Ouellette - '10
Bill Rogers - '10
Zolton Sachs - '10
Paul St. James - '10

Webmaster – Bill Fastiggi

MBBC Racing Program

Race Committee Coordinators

| RACE | COORDINATOR |
|--------------------------|-----------------|
| Coffee Pot Race | Geoff Halsted |
| Sunday One Design Races | Arnold Tran |
| Jr. Race Series | Heather Ambrose |
| Tuesday Laser Races | Al Russell |
| Midweek Summer Series | Rod Carr |
| Spring Lightning Regatta | Arnold Tran |
| Double Handed Race | Mike Quaid |
| Royal Savage | Al Baker |
| Long Distance Race | Geoff Halsted |
| Ethan Allen Regatta | Todd Cox |
| Chiott Regatta | Al Russell |
| Lake Champlain Race | Mark Gardner |
| Finch Cup | Alan Ouellette |
| Corrections Cup | Bob Drawbaugh |
| Fall Midweek Series | Rod Carr |
| Cystic Fibrosis Regatta | Gerry Couture |
| Benedict Arnold Race | Patrick Zachary |
| Leaf Peeper Regatta | Geoff Halsted |
| Lightning Jr. Clinics | Heather Ambrose |
| J24 Frostbite | Alan Ouellette |

Lake Champlain PHRF Committee Representatives:

Rod Carr, Geoff Halsted, Alan Ouellette

Race Schedule

| Race | Class | Date | Time | Day | Coordinator |
|--|--------------------|---------------|-------------|--------------|--------------------|
| Laser Series 1 | Board Boat | 5/13 | 1800 | Tues | Pete Abele |
| Laser Series 2 | Board Boat | 5/20 | 1800 | Tues | Sarah Gallagher |
| Coffee Pot | PHRF | 5/24 | 0900 | Sat | Geoff Halsted |
| One Design 1 | One Design | 5/26 | 1030 | Mon | Charly Dickerson |
| Laser Series 3 | Board Boat | 5/27 | 1800 | Tues | Dave Hazelett |
| Midweek 1 | One Design PHRF | 5/29 | 1815 | Thurs | Martin Olsen |
| Spring Lightning Regatta | One Design | 5/31 - 6/1 | 1000 | Sat - Sun | Martin Olsen |
| Laser Series 4 | Board Boat | 6/3 | 1800 | Tues | Sarah Gallagher |
| Midweek 2 | One Design PHRF | 6/5 | 1815 | Thurs | Al Russell |
| Laser Series 5 | Board Boat | 6/10 | 1800 | Tues | Charly Dickerson |
| Midweek 3 | One Design PHRF | 6/12 | 1815 | Thurs | Mike Birnbaum |
| Double-Handed | PHRF | 6/14 | 0900 | Sat | Mike Quaid |
| One-Design 2 | One Design | 6/15 | 1030 | Sun | Al Russell |
| Laser Series 6 | Board Boat | 6/17 | 1800 | Tues | Al Hobart |
| Midweek 4 | One Design PHRF | 6/19 | 1815 | Thurs | Harry Reindel |
| Royal Savage LCPHRF Championship 1 | PHRF | 6/21 | 1030 | Sat | Al Baker |
| Lightning Jr. Clinic 1 | One Design | 6/23 | 1800 | Mon | Heather Ambrose |
| Laser Series 7 | Board Boat | 6/24 | 1800 | Tues | Sarah Gallagher |
| Midweek 5 | One Design PHRF | 6/26 | 1815 | Thurs | Tim Ambrose |
| Long Distance Race | PHRF | 6/28 | | Sat | Geoff Halsted |
| One-Design 3 | One Design | 6/29 | 1030 | Sun | Robert Drawbaugh |
| Laser Series 8 | Board Boat | 7/1 | 1800 | Tues | Mike Birnbaum |
| Midweek 6 | One Design PHRF | 7/3 | 1815 | Thurs | Arnie Tran |
| Ethan Allen Race | PHRF | 7/4 | 1300 | Tues | Janice Lange |
| Jr. Race Series 1 | Board Boat | 7/7 | 1800 | Mon | |
| Laser Series 9 | Board Boat | 7/8 | 1800 | Tues | Rod Carr |

| Race | Class | Date | Time | Day | Coordinator |
|---|--------------------|----------------|------|--------------|-----------------|
| Midweek 7 | One Design PHRF | 7/10 | 1815 | Thurs | Mark Gardner |
| NE W,J,M Lightning Districts | Away | 7/11 | | Fri | Arnold Tran |
| NE Lightning District | Away | 7/12 – 7/13 | | Sat- Sun | Arnold Tran |
| Mayor's Cup Plattsburgh LCPHRF Championship 2 | PHRF - Away | 7/12 | | Sat | |
| Laser Series 10 | Board Boat | 7/15 | 1800 | Tues | Scott Beaudin |
| Midweek 8 | One Design PHRF | 7/17 | 1815 | Thurs | Al Baker |
| Lake Champlain Race LCPHRF Championship 3 | PHRF | 7/18- 7/19 | 2000 | Fri - Sat | Geoff Halsted |
| Finch Cup | PHRF | 7/20 | 0900 | Sun | Alan Ouellette |
| One Design 4 | One Design | 7/20 | 1400 | Sun | Ken Grillo |
| Lightning Jr. Clinic 2 | One Design | 7/21 | 1800 | Mon | Heather Ambrose |
| Laser Series 11 | Board Boat | 7/22 | 1800 | Tues | Bill Rogers |
| Midweek 9 | One Design PHRF | 7/24 | 1815 | Thurs | Gerry Couture |
| Regatta for Lake Champlain | PHRF | 7/26 | TBA | Sat | Mark Gardner |
| Laser Series 12 | Board Boat | 7/29 | 1800 | Tues | Mark Gardner |
| Midweek 10 | One Design PHRF | 7/31 | 1815 | Thurs | Marcy Milton |
| Martin 16 Regatta | One Design | 8/1 - 8/3 | | Fri - Sun | Mark Gardner |
| Ladies Cup LCYC LCPHRF Championship 4 | PHRF | 8/2 | | Sat | |
| Jr. Race Series 2 | Board Boat | 8/4 | 1800 | Mon | |
| Laser Series 13 | Board Boat | 8/5 | 1800 | Tues | Janice Lange |
| Midweek 11 | One Design PHRF | 8/7 | 1815 | Thurs | Bill Rogers |
| Lightning Jr. Clinic 3 | One Design | 8/11 | 1800 | Mon | Heather Ambrose |
| Laser Series 14 | Board Boat | 8/12 | 1800 | Tues | Harry Reindel |
| Corrections Cup | PHRF | 8/15 | 1030 | Fri | Bob Drawbaugh |

Race Schedule

| Race | Class | Date | Time | Day | Coordinator |
|--|--------------------|----------------|------|--------------|------------------|
| Midweek 12 | One Design PHRF | 8/14 | 1815 | Thurs | Dave Jillson |
| Chiott Regatta (Vermont Open Laser Regatta) | One Design | 8/16- 8/17 | 0900 | Sat- Sun | Al Russell |
| Laser Series 15 | Board Boat | 8/19 | 1800 | Tues | Mark Gardner |
| Midweek 13 | One Design PHRF | 8/21 | 1815 | Thurs | Patrick Zachary |
| J24 Districts | One Design | 8/23 - 8/24 | 0900 | Sat - Sun | Alan Ouellette |
| Laser Series 16 | Board Boat | 8/26 | 1800 | Tues | Todd Cox |
| Midweek 14 | One Design PHRF | 8/28 | 1815 | Thurs | Todd Cox |
| Laser Series 17 | Board Boat | 9/2 | 1800 | Tues | Al Hobart |
| Fall Midweek 1 | One Design PHRF | 9/4 | 1800 | Thurs | Rod Carr |
| Cystic Fibrosis Regatta | One Design PHRF | 9/6 | 1300 | Sat | Gerry Couture |
| Laser Series 18 | Board Boat | 9/9 | 1800 | Tues | Bill Hickson |
| Fall Midweek 2 | One Design PHRF | 9/11 | 1800 | Thurs | Gerry Davis |
| Macdonough Race LCYC – LCPHRF Championship 5 | PHRF | 9/13- 9/14 | | Sat - Sun | LCYC |
| One Design 5 | One Design | 9/14 | 1300 | Sun | Rod Carr |
| Laser Series 19 | Board Boat | 9/16 | 1800 | Tues | Ken Felis |
| Fall Midweek 3 | One Design PHRF | 9/18 | 1800 | Thurs | Bob Drawbaugh |
| Laser Series 20 | Board Boat | 9/23 | 1800 | Tues | Bill Rogers |
| Fall Midweek 4 | PHRF | 9/25 | 1800 | Thurs | Bill Fastiggi |
| MBBC Fall Invitational | One Design | 9/27- 9/28 | 0900 | Sat - Sun | Martin Olsen |
| Laser Series 21 | Board Boat | 9/30 | 1800 | Tues | Sarah Gallagher |
| Benedict Arnold | PHRF | 10/4 | 1100 | Sat | Patrick Zachary |
| Leaf Peeper Regatta | One Design | 10/11 | 0900 | Sat - Sun | Geoff Halsted |
| Late Fall J24 Series 1 | One Design | 10/25 | 1300 | Sat | Charly Dickerson |

| Race | Class | Date | Time | Day | Coordinator |
|------------------------|----------------------------------|--------|------|-----|------------------|
| Late Fall J24 Series 2 | One Design | 11/1 | 1300 | Sat | Charly Dickerson |
| Awards Banquet | Wyndham Hotel, Burlington, VT | 11/15 | | Sat | Heather Ambrose |
| Late Fall J24 Series 3 | One Design | 11/8 | 1300 | Sat | Charly Dickerson |
| Late Fall J24 Series 4 | One Design | 11/15 | 1300 | Sat | Charly Dickerson |
| Late Fall J24 Series 5 | One Design | 11/122 | 1300 | Sat | Charly Dickerson |

Notice of Regatta and Sailing Instructions

1. Eligibility:

Each boat must conform to the rules of the class to which it belongs as to measurement, equipment and crew. In the case of one-design classes, the national authority rulings shall pertain. In the case of cruising boats racing under PHRF Handicap, the rules of PHRF Lake Champlain shall pertain.

2. Rules:

The Racing Rules of Sailing, as adopted by the U.S. Sailing Association, plus all instructions listed below. Modifications to these race instructions will be posted no later than 1 hour prior to the Warning Signal.

3. Skippers' Meeting:

Only when required by the Notice of Race.

4. Marks:

Orange, Green or Yellow marks will be used for races located within Malletts Bay. Letters are used to designate the marks (see chart on inside cover). An inflatable buoy may be tethered to the stern of the committee boat(s). This buoy will be considered part of the Race Committee boat. Government marks and islands may be used for cruising class or long distance races.

5. Starting Signals: See Page 75 for more details

Racing Rules of Sailing "26 Starting Races"

5a. Class Flags

"Class A-B" Red, "Class C/D" Yellow, "Class D" Gray, "Class N" White, J-24 "Green", "Lighting" Pink, Laser, "Gray

6. Sail Numbers:

Sail numbers are required in all races.

7. Additional Signals:

Postponed: Answering Pennant (red & white vertical bars) means "Race Postponed". The race may be started later the same day.

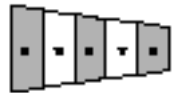

Canceled: Code Flag "N" (blue and white checkered) means "Race Canceled", return to Club.

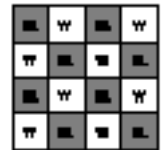

Shortened: Code Flag "S" (white with blue square) means "Shortened Course". At its discretion, the Race Committee may shorten course at any mark prior to the first boat passing or rounding that mark. The Race Committee boat will establish its position at said mark by displaying Code Flag "S" and sounding two signals with the cannon or horn. The finish line will be between the Race Committee boat and the mark. The Committee Boat may anchor on either side of the mark.

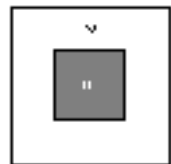

General Recall: When at the starting signal the Race Committee is unable to identify boats that are on the course side of the starting line or to which rule 30 applies, or there has been an error in the starting procedure,

the Race Committee may signal a General Recall [display the First Substitute (blue & yellow triangle) with two sounds]. The warning signal for the new start for the recalled class shall be made one minute after the First Substitute is removed (with one sound). If there are multiple class starts, the recalled class's start will be moved to the end of the starting sequence.



Individual Recall: Code Flag "X" (blue cross on a white field) means "Individual Recall". The Race Committee will sound one signal to call attention to the flag, which indicates an individual boat or several boats are over early. The Race Committee will attempt to hail the boat(s) over early. However, it is the individual skipper's responsibility to start properly. The code flag "X" will stay up until all boats have started properly or for four minutes after the starting signal, whichever is earlier.

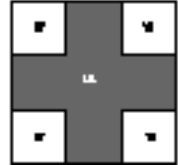

Life Jackets: Code Flag "Y" (red and yellow diagonal bars) means all crews must put on Coast Guard approved life jackets or be disqualified.

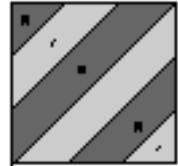

Radio Communications: The Race Committee may use VHF channel 12 to broadcast race information. The Race Committee may attempt to identify premature keelboat starters by broadcast their sail numbers on VHF channel 12. Failure of a boat to see, hear, or interpret a recall notification shall not relieve her of the obligation to properly start, nor shall it be grounds for redress under RRS 62. A boat's position in the sequence of broadcast numbers or failure of the Race Committee to broadcast recall numbers shall not be grounds for redress.

8. Protests:

Any boat wishing to protest another boat should so indicate by doing all of the following:

- Hail the crew of the other boat to inform them of the protest. If it is not possible, notify the other boat's crew at the first reasonable opportunity.
- Promptly fly an all red protest flag. However, boats of hull length less than 19'8" need not display the flag.
- Notify the Race Committee immediately after the race. Except in unusual circumstances, a written protest must be filed with the Race Committee within 30 minutes of the Race Committee boat's return to the Club.

Whenever possible, protests will be heard by a Protest Committee appointed by the Race Committee of the Day right after the racing is finished for that day. All such protests must be in writing, must include: the name of the protestor, the name of the protested, and the specific rule which is alleged to have been infringed.

When the above procedure cannot be followed, all written protests must be mailed to the Club Race Committee Chairman and must be post-marked within 24 hours (excepting Sundays and holidays). Upon receipt of such written requests, the Chairman will contact both parties and designate a time and place for a protest hearing. Any Club member who wishes to have the opinion of the Race Chairman regarding any rule interpretation may request the same by writing to the Race Chairman with the appropriate description. Please note that such a request does not

constitute a protest.

Racing boats will inevitably sail, at times, out of sight of one another and the person in charge may be the sole judge of fair play. When accepting a trophy, he or she must be satisfied that the race has been sailed in complete obedience to all rules for that race, or must advise the Race Committee of any variance.

9. Tie-Breaking Procedure:

Races that tie: If boats are tied at the finish line or if a handicap system is used and boats have equal corrected times, the points for the place for which the boats have tied and for the places immediately below shall be added together and divided equally. Boats tied for a race prize shall share it or be given equal prizes.

Series that tie (Regatta): If there is a series score tie between two or more boats, each boat's race scores shall be listed in order of best to worst, and at the first point(s) where there is a difference the tie shall be broken in favor of the boat(s) with the best score(s). No excluded scores shall be used. If a tie remains between two boats, it shall be broken in favor of the boat that scored better than the other boat in more races. If more than two boats are tied, they shall be ranked in order of the number of times each boat scored better than another of the tied boats. No race for which a tied boat's score has been excluded shall be used. If a tie still remains between two or more boats, they shall be ranked in order of their scores in the last race. Any remaining ties shall be broken by using the tied boats' scores in the next-to-last race and so on until all ties are broken. These scores shall be used even if some of them are excluded scores.

Series that tie (longer than a Regatta): For a series that is held over a period of time longer than a regatta, a boat that came to the starting area but did not start, did not finish, retired after finishing or was disqualified shall be scored points for the finishing place one more than the number of boats that came to the starting area. A boat that did not come to the starting area shall be scored points for the finishing place one more than the number of boats entered in the series.

10. Errors in Results:

The Race Committee takes every precaution to ensure that the race results are correct. However, errors are made. Please check the results of all races that you sail in carefully and report any errors to the Club Race Chairman. Errors not found and reported after two weeks from the publication of results shall stand as published.

11. Appeal Procedure:

Your right to appeal as detailed by The Racing rules of Sailing for 2005-2008 ISAF Section D -Appeals 70 Right of Appeal and Requests for Interpretation.

12. Handicaps:

Two handicap systems are established for boats of various types:

a. PHRF

This is the handicap system for inter-club cruising boat competition on Lake Champlain and also for some of the cruising boat races of MBBC. This nationally based performance handicap system is a time on distance or time on time handicap, which is modified and administered by regional groups. Local handicappers (three members each from Malletts Bay Boat Club, Lake Champlain Yacht Club, and Valcour Sailing Club) set the ratings. If you want to

race your boat under this system, you must apply for a PHRF Lake Champlain handicap for your boat. Application forms are available from PHRF handicappers.

b. PORTSMOUTH

Centerboard boats will use the Portsmouth ratings found in the USSA Portsmouth Yardstick.

13. Awards:

Many beautiful trophies are awarded each racing season. Perpetual trophies include: the "informal" Coffee Pot, the historical Corlaer, Royal Savage and Ted Brooks Trophies, the classic Chiott Cup, Benedict Arnold Trophy, Lake Champlain Race and Long Distance Race Trophies, Seamanship Trophy, Bob Sidle - Emerson Trophies and the "Chris Davis Trophy" for the Double-Handed Race.

A "keeper" trophy will be awarded to you if you finish in the top three in class in most races. It may be an individual trophy for this race and/or an award with all your season's results recorded on it. And don't forget our special award - The Moosehead - is looking at you!

14. Safety:

Each competitor is solely responsible for his or her own safety. All boats must be in compliance with Coast Guard safety regulations and the rules for inland water-ways. Boats unable to comply must retire or face disqualification under The Racing Rules of Sailing for 2005-2008 ISAF Part 1 Rule 1.2. A boat which retires from a race is asked to attempt to notify the Race Committee. Remember that "the rules of the road" DO NOT necessarily give a racing boat the "right of way". Please be courteous to other boaters and stay clear of boats not participating in the race.

15. Race Committee Recommendations:

It is the desire of the race committee to assist all competitors to be safe when on the water. However, the ultimate responsibility rests with the skipper/owner of each individual boat. The following are guidelines under which an individual race committee may act to cancel, or postpone a race due to weather conditions. If possible, a harbor postponement is preferable to a race course postponement.

a. No wind for Thursday night races: In the event there is no wind at the time of the first warning gun, the race committee should hoist the postponement flag. If there is no wind, or prospect for wind 30 minutes after the scheduled start of the first class, the race committee should cancel all starts.

b. No wind for day races: In the event there is no wind at the time of the scheduled first warning gun, the race committee should hoist the postponement flag. If there is no wind, or prospect for wind one hour after the scheduled start of the first class, the race committee should cancel all starts.

c. Abandonment: In the event that conditions become so extreme that the race committee fears for the overall safety of racers, and/or for itself, all races in progress should be abandoned.

d. Abandonment due to rain: Although rain can be a nuisance, it is not cause for abandoning a race. Rain is not a race committee concern.

e. Abandonment due to lightning: Visible lightning moving towards the race course is cause for postponement or cancellation. Lightning in the race area is cause for immediate abandonment.

f. Life jackets required: The skipper of a boat has the ultimate responsibility to require the wearing of life jackets on board his/her boat. The decision to do so should be based on crew experience, weather conditions, day or night sailing, crew comfort level, and number of crew available. However, if wind velocities are exceeding twenty knots at or before the warning signal for a class, the race committee may require the use of life jackets by hoisting the "Y" flag and making one sound signal.

16. Class N Rule:

For purposes of sailing in "N" class (non-spinnaker), rule numbers 50.2 and 50.3 shall be waived and not in effect.

Races for One-Design Classes

1. One-Design Series

General Description:

A series for Lightnings, J-24's, and any other one-design class of three or more starters. Format to be announced.

Scoring:

Series will be scored by each class according to their individual requirements.

Courses:

Races will be on a triangular or windward/leeward course (Figure 2) located on Inner or Outer Malletts Bay at Race Committee's discretion. Courses will be indicated by appropriate numbers and/or letters displayed on the Race Committee boat marker board. If only numbers are used, all marks will be kept to port. If numbers and letters are used, the number given first refers to one of the course diagrams. The letters following the number refer to the race marks (Figure 1) in the order to be rounded. The marker board should always be read from bow to stern on the Race Committee boat. For course 7, the starting mark is used only for the start and finish. Any course may be modified to use a mid course start/finish line (as in course 7) by displaying the letter "M".

Example: 2BCA

2 - refers to course #2 which is a triangle followed by windward, leeward.

B - 1st mark to be rounded.

C - 2nd mark to be rounded.

A - 3rd mark to be rounded.

Course #2 indicates "B" is to be rounded again with the finish back at "A".

Start:

1030

Finish:

Between a mark and the Race Committee boat.

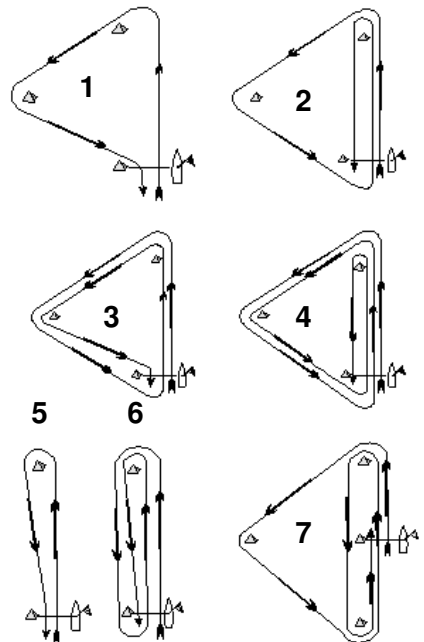
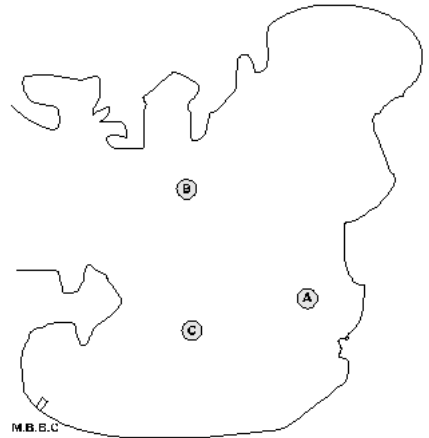

2. Chiott Regatta

General Description:

MBBC's major one-design, two-day regatta. It is open to club and non-club sailors.

Date:

Saturday August 16 & Sunday August 17, 2008

Eligibility:

Any one-design class with 3 or more entries.

Classes:

For 2008, the Afterguard has selected the Laser class to race for the Chiott Cup. Other classes will be determined at the skippers' meeting.

Registration:

At club house, 0900

Skippers' Meeting:

1000 on Saturday only.

Course:

The course will be determined at the skippers' meeting.

Starting Times and Sequence:

To be determined at the skippers' meeting.

Scoring:

The series will be scored using The Racing Rules of Sailing for 2005-2008 ISAF Rule 89.3 appendix A. If six or more races are completed, one race will be discarded.

Awards:

The Chiott Cup is awarded to the winner of the class that has been selected by the Afterguard. Selection is made after classes have petitioned the Afterguard for the privilege to race for the Cup. Individual prizes will be awarded after the racing to the first 3 boats in each class.

3. Tuesday Evening Laser Series

General Description: An evening series for Lasers and other board boats.

Dates: See Schedule

Eligibility: Open to members and non-members.

Classes: Any board class with 3 or more boats.

Registration: At the Race Committee Boat

Course: Same as One-Design Series.

Starting Times and Sequence:

First Warning Signal is at 1800.

Course and postponement signals may be made orally. Audible signals shall govern, even when supplemental visual signals are also used. The starting sequence shall consist of the following sound signals made at the indicated times:

Signal Sound – Time before start

Warning: 3 long – 3 minutes

Preparatory: 2 long – 2 minutes

1 long & 3 short – 1 minute 30 seconds

1 long – 1 minute

3 short – 30 seconds

2 short – 20 seconds

1 short – 10 seconds

1 short – 5 seconds

1 short – 4 seconds

1 short – 3 seconds

1 short – 2 seconds

1 short – 1 second

Start: 1 long

Signals shall be timed from their commencement. A series of short signals may be made before the sequence begins in order to attract attention. Individual recalls shall be signaled by the hail of the sail number (or some other clearly distinguishing feature) of each recalled boat. Flag X need not be displayed. Failure of a competitor to hear an adequate course, postponement, starting sequence or recall signal shall not be grounds for redress.

Scoring:

The Racing Rules of Sailing for 2005-2008 ISAF Rule 89.3 and Appendix A. Each boat's series score shall be the total excluding 25% of the worst scores. Any fraction will be rounded up. If a boat has two or more equal worst scores, the score(s) for the race(s) sailed earliest in the series shall be excluded. The boat with the lowest series score wins and others shall be ranked accordingly. Canceled races do not count in the overall score.

Award: The Lake Champlain Laser Fleet Trophy

PHRF Series

Midweek and Fall Series

General Instructions

Eligibility: Open to all pre-registered boats. Traditionally, this series provides informal racing and provides the beginning racer or the owner of a non-class boat the opportunity to participate.

Registration: Available to all boats - Check in with the Race Committee

Classes:

- Class A: Spinnaker (full race) PHRF Handicap 99 and lower.
- Class B: Spinnaker (full race) PHRF Handicap 102-141.
- Class C: Spinnaker (full race) PHRF Handicap 144-177
- Class D: Spinnaker (full race) PHRF Handicap 180 and higher
- Class N: Non-spinnaker (maximum rated PHRF genoa)
- Class J: J24 One Design Class
- Class L: Centerboard boats normally sailed by a crew of two or more.
National Portsmouth Handicap

Note 1: Flashers and similar cruising spinnaker-type sails will be considered as spinnakers for these races.

Note 2: Boats racing in class N should fly a visible white pennant from the backstay from the time of the warning signal until the race is completed.

Start Location: (Midweek and Fall Series) Inner Malletts Bay.

Courses: Same as for the One-Design Series.

Protests:

Protest hearings will be held as soon as possible and the results will be posted. For protests involving an alleged breach of a rule of Part 2, where there is no damage, the parties involved in the protest may opt for arbitration. One representative of each party shall meet with a mutually agreed upon arbitrator. After taking testimony from each representative, the arbitrator will decide either: a) No boat broke a rule. If the representatives agree, the protest is withdrawn. If any representative disagrees, the jury will schedule a protest hearing. b) One or both boats broke a rule. The representative(s) of the boat(s) breaking a rule agree to withdraw from the race and will be scored as RAF and the protest will be withdrawn. If any representative disagrees, the jury will schedule a protest hearing. c) The protest does not qualify for arbitration. The jury will schedule a protest hearing. If the protest is withdrawn, the arbitration will neither be reopened nor grounds for redress. This changes RRS 62.1(a). The arbitrator may be present in the protest hearing as an observer but will not take part in the decision of the jury.

Scoring:

All keel boat classes will use PHRF time-on-time handicap. Centerboard boats will use the National Portsmouth Handicap. Scoring will be low point using The Racing

Rules of Sailing for 2005-2008 ISAF Rule 88.3 and Appendix A. The race committee of the day will be scored as if they had raced and will receive 1 point. This will not affect the scores of the race.

For these series, any boat that came to the starting area but did not start, did not finish, retired after finishing or was disqualified shall be scored points for the finishing place one more than the number of boats that came to the starting area. A boat that did not come to the starting area shall be scored points for the finishing place one more than the number of boats entered in the series.

1. Midweek Summer Series

General Description: A Summer series of Thursday evening races.

Eligibility: Open to all pre-registered boats, sailing in Class A/B, J/24, C/D, N, or L

Classes, Starting Times, and Sequence:

See Page 75 for explanation of Starting Sequence

Harbor Start: 1730

| Class | Flag | Warning | Preparatory | Start |
|-------|--------|---------|-------------|-------|
| N | White | 1810 | 1811 | 1815 |
| L | Pink | 1815 | 1816 | 1820 |
| C & D | Yellow | 1820 | 1821 | 1825 |
| A & B | Red | 1825 | 1826 | 1830 |
| J | Green | 1830 | 1831 | 1835 |

Courses and Location:

The Race Committee will attempt to choose a start location that will give the best initial windward leg. Watch for the Race Committee boat and leeward mark at a logical downwind position. The course will be displayed on the Race Committee Boat.

Overall Series Scoring:

All boats in a start will be scored together as a class. Each boat's series score shall be the total excluding 20% of the worst scores. If a boat has two or more equal worst scores, the score(s) for the race(s) sailed earliest in the series shall be excluded. The boat with the lowest series score wins and others shall be ranked accordingly. Canceled races do not count in the overall score.

Monthly Series Scoring:

Each class will be scored as a monthly series. All races will count.

Time Limit:

No boats will be finished after ½ hour after sunset.

Awards:

For 2008, the Gordon Anger Trophy will be awarded to first in class L for the season. Awards will be conferred on the top three finishers of each class for the season. Awards will be given for the monthly series.

2. Midweek Fall Series

General Description: A Fall series of Thursday evening races.

Eligibility: Open to all pre-registered boats, sailing in Class A/B, C/D, L, or N

Scoring:

Each boat's series score shall be the total of her race scores excluding her worst score. If a boat has two or more equal worst scores, the score(s) for the race(s) sailed earliest in the series shall be excluded. The boat with the lowest series score wins and others shall be ranked accordingly.

Classes, Starting Times, and Sequences:

See Page 75 for explanation of Starting Sequence

| Class | Flag | Warning | Preparatory | Start |
|--------------|-------|---------|-------------|-------|
| L & N | White | 1755 | 1756 | 1800 |
| A/B - C/D -J | Red | 1800 | 1801 | 1805 |

Start Location:

Inner Malletts Bay Racing Mark "C". Start may be either a windward or leeward start.

Time Limit:

There will be a 1½ hour time limit for each boat from the start of its class.

Course:

Course will be number six (6); windward - leeward, twice around.

Awards:

Awards will be presented to the top three place finishers of each class for the series.

PHRF Races and Regattas

1. Coffee Pot Race

Date: Saturday May 24

General Description: The traditional season opener. Be prepared for possible cold conditions. The Coffee Pot will be scored as a multiple race regatta.

Eligibility: Open to all PHRF boats.

Classes: Spinnaker and Non-Spinnaker

Course:

The course(s) to be used will be posted on the board at the end of the dock by 0900. The available courses are 1-7, as described in the Log under "Courses for One-Design Races," or Race Course C.

Race Course C:

1. Start in the Inner Bay between RC Boat and orange pin marker
2. Stave Island to Port
3. Jones Rock to Port
4. Finish Between RC Boat and orange pin marker

If Race Course C is used, the RC may shorten the race in the Outer Bay in the vicinity of the Cut between the Outer Bay and the Broad Lake.

Start Location:

The course may be located on the Inner or Outer Malletts Bay at the discretion of the Race Committee. The location will be posted on the chalk board at the end of the dock by 0900. The first warning signal for the final race will be no later than 1530.

Starting Times and Sequence:

See Page 75 for explanation of Starting Sequence. Class Flag is "White"

| Class | Flag | Warning | Preparatory | Start |
|-------|-------|---------|-------------|-------|
| All | White | 1000 | 1001 | 1005 |

Note:

Starting times will be 30 minutes later if the race is sailed on Outer Malletts Bay.

Scoring:

All Classes will use PHRF time-on-time handicap and will be scored using The Racing Rules of Sailing for 2005-2008 ISAF Rule 88.3 and Appendix A.

Awards:

The Coffee Pot will be awarded to the overall winner.

2. Double-Handed Race

Date: Saturday, June 14

General Description: A double-handed race for boats in Malletts Bay open to all keel boats normally crewed by two or more people.

Eligibility: Any class/fleet with two or more boats may race.

Classes: To be determined at Skipper's meeting.

Skippers' Meeting: 0900 hours

Course: Same as One-Design Series.

Starting Times and Sequence:

See Page 75 for explanation of Starting Sequence

| Warning | Preparatory | Start |
|---------|-------------|-------|
| 1025 | 1026 | 1030 |

Notes:

There will be separate starts for non-spinnaker keel boats and/or Portsmouth handicapped centerboard boats if there are 3 or more boats in each class. There may be multiple races at the discretion of the Race Committee.

Scoring:

PHRF classes will use PHRF time-on-time handicap and will be scored using The Racing Rules of Sailing for 2005-2008 ISAF Rule 89.3 and Appendix A.

Awards:

The "Chris Davis Memorial Trophy" is awarded to the top boat in the PHRF Spinnaker Class.

3. Royal Savage Regatta

Date: Saturday - June 21

General Description: A two-race event held on Outer Malletts Bay.

The Royal Savage Trophy is one of the most historically significant trophies awarded to sailors on Lake Champlain. The trophy consists of a glass encased relic from the Sloop Royal Savage, the first American Vessel to engage the enemy at the Battle of Valcour on October 11, 1776.

Eligibility: Open to all PHRF boats.

Classes: Classes A, B, C, D and non-spinnaker. Any PHRF fleet with two or more boats.

Registration: 0800 to 0900.

Non MBBC members may register at the Race Committee Boat.

Race Instructions: Available during registration and at the Race Committee Boat

Course: As per race instructions

Harbor Start: 0930

Start Time: First Warning Gun at 1030

Awards:

The Royal Savage Trophy is awarded to the boat finishing first for the combined total overall in Classes A & B.

The Ted Brooks Trophy will be awarded to the boat finishing first for the combined total overall in Classes C & D.

4. Long Distance Race

Date: Saturday – June 28

Competitors Meeting: 0830 hours

General Description: A single race will be held on Saturday June 28th.

No spinnakers or bloopers will be allowed. Boats may not use more than one headsail at a time and that headsail shall not be larger than their maximum PHRF rated genoa.

A rendezvous will be held on Saturday night near Stave Island or some other suitable anchorage in that area for race participants, MBBC cruisers, and others.

Classes: One Division for all boats.

NOTE: Adjustments to PHRF base ratings will be made for cruising gear, dinghys, and other issues.

Course:

Start in Inner Malletts Bay and finish near the anchorage around Stave Island. An exact course will be determined based on anticipated conditions and participation as the day of the event approaches and will be announced at the Skippers Meeting and posted on the regatta notice board before 0900.

Starting Time:

1000 hours -Warning Signal for all Classes

1005 hours -Starting Signal for all Classes

Awards:

The Long Distance Race Trophy and fun prizes will be awarded after the race.

5. Ethan Allen Regatta

Date: Wednesday - July 2**General Description:** An open regatta, raced using no spinnakers or bloopers.**Eligibility:** Any PHRF boat. Non-club sailors are welcome to participate.**Course:** To be announced at the end of registration**Registration:** 1000 to 1100 hours at MBBC.

Please try to pre-register via email to ghalsted1@yahoo.com anytime after June 1 and before 0900 hours July 1. [Just type "Ethan Allen Regatta" in the subject and tell me your name, boat name and boat type in the email.]

Starting Time: Individual start times based on your PHRF rating will be assigned at registration and the first boat to finish wins!

| Flag | Warning | Preparatory | Start |
|-------|---------|-------------|-------|
| White | 1155 | 1156 | 1200 |

Scoring:

The race will be scored using The Racing Rules of Sailing for 2005-2008 ISAF Rule 88.3 and Appendix A.

Awards: Presented directly after the race.

6. Lake Champlain Race

Date: Friday – Saturday, July 18 – 19**General Description:** The Lake Champlain Race exposes the racer to the northern sections of Lake Champlain. Information for the Lake Champlain Race can be obtained from Geoff Halsted: (802) 310-2961.**Eligibility:** Open to all PHRF boats.**Scoring:** All classes will use PHRF time-on-time handicap and will be scored using The Racing Rules of Sailing for 2005-2008 ISAF Rule 89.3 and Appendix A.**Classes:** Classes A, B, C, D and non-spinnaker as determined by Lake Champlain PHRF.**Registration:** At the Race Committee boat on the starting line.

There is no skippers' meeting. The Race Committee will monitor VHF channel 12.

Start Location:

Between the Race Committee boat and a starting mark northeast of Stave Island. Each yacht racing is asked to pass the committee boat to synchronize their time piece with the official race time. This will help to provide more accurate finish times if there is not a race committee boat on site at the finish.

Starting Times:

See Page 75 for explanation of Starting Sequence. Class Flag is "White".

| Class | Flag | Warning | Preparatory | Start |
|-------------|-------|---------|-------------|-------|
| All Classes | White | 2000 | 2001 | 2005 |

Race Course:

- Start Between RC Boat and orange pin marker
 - RN "2" at Stave Island to PORT
 - RN "28" Garden Island Ledge to STBD
 - RN "20" La Roche Reef to PORT
 - Schuyler Island to PORT
 - Juniper Island to STBD
 - The Four Brothers to STBD
 - Crab Island to STBD
 - Finish Line at RN 2 and Carlton Prize
- Total Distance: 62 Nautical Miles

Shortened Course: The Race Committee may shorten the race at any mark.

Time Limit: One boat finishing in any class will make the race valid for that class. Time limit will be 1900 on July 28.

Finish Line: Finish line will be between the Race Committee boat and a pin mark Northeast of Stave Island (Bird Rock.)

If the Race Committee boat is not on station, the finish will be between RN "2" (Bird Rock) and Carleton's Prize. In the event that a Race Committee boat is not present at the finish line, it will be the responsibility of the boat finishing to record it's own finish time and to then report it to the Race Committee by contacting Geoff Halsted: (802) 310-2961. Finish times must be recorded as the actual time finished, not the elapsed time of the race.

Protests:

Protests must be filed at the Race Committee boat at the finish, or by phone or e-mail to Geoff Halsted by 2000 hrs. On July 28. All protests will be heard at MBBC on July 31st at 2030 hrs.

Awards:

The Lake Champlain Trophy will be awarded to the boat which sails the course with the lowest corrected time.

7. Finch Cup

Date: Sunday - July 20

General Description: An open regatta, raced using no spinnakers or bloopers.

Eligibility: Any PHRF boat. Non-club sailors are welcome to participate. The boat must be helmed by a woman or Junior sailor.

Course: To be announced at the end of registration

Registration: 0900 to 1000 hours at MBBC.

Please try to pre-register via email to ghalsted1@yahoo.com anytime after June 1 and before 0900 hours July 12. [Just type "Finch Cup" in the subject and tell me your name, boat name and boat type in the email.]

Starting Time:

Individual start times based on your PHRF rating will be assigned at registration and the first boat to finish wins!

| Flag | Warning | Preparatory | Start |
|-------|---------|-------------|-------|
| White | 1055 | 1056 | 1100 |

Scoring:

The race will be scored using The Racing Rules of Sailing for 2005-2008 ISAF Rule 88.3 and Appendix A.

Awards: Presented directly after the race.

8. State Employees/Corrections Cup

Date: Friday, August 15

General Description: Started in 1986 and held during the week of Bennington Battle Day as a friendly competition among State Employees, this regatta is open to any wind powered vessel. Spinnakers are permitted.

Eligibility: MBBC members as well as non-members, employed or retained by the state and who own their vessel or who skipper another's with at least one state employee crew. Retirees and Health Plan eligible persons may also enter.

Registration: 1000 to 1100 hours at MBBC.

Please try to pre-register via email to RodCarr32@aol.com anytime after June 1 and before 0900 hours August 15. [Just type "Corrections Cup" in the subject and tell me your name, boat name and boat type in the email.]

There will be two classes, with and without spinnaker.

Skippers' Meeting: 1030

Harbor Start: 1100

Course: Inner Malletts Bay, to be announced at Registration.

Starting Time:

Individual start times based on your PHRF rating will be assigned at registration and the first boat to finish wins!

| Flag | Warning | Preparatory | Start |
|-------|---------|-------------|-------|
| White | 1155 | 1156 | 1200 |

Scoring:

The race will be scored using The Racing Rules of Sailing for 2005-2008 ISAF Rule 88.3 and Appendix A.

Awards:

Corrections' Cup trophy awarded to the winner in the spinnaker class right after the race.

9. Sailing For Cystic Fibrosis Knotta Regatta

Date: Saturday – September 6

General Description: A two-race event held on Outer Malletts Bay.

The Knotta Regatta is held to raise awareness and funds for people with cystic fibrosis (CF) in the greater Burlington area. A reception cookout and fundraiser event will be held immediately following the races. Contact Gerry Couture for more information.

Eligibility: Open to all PHRF boats.

Classes: Classes A, B, C, D and non-spinnaker. Any PHRF fleet with two or more boats.

Registration: 0800 to 0900.

Non MBBC members may register at the Race Committee Boat.

Race Instructions: Available during registration and at the Race Committee Boat

Course: As per race instructions

Harbor Start: 0930

Start Time: First Warning Gun at 1030

Awards: Presented directly after the race

10. Benedict Arnold Race

Date: Saturday, October 4

General Description:

This race commemorates the Revolutionary War naval Battle of Valcour which occurred on Friday, October 11, 1776 between an American fleet commanded by Benedict Arnold and a British fleet under the authority of Sir Guy Carleton, though he was not the operational commander.

The weather that day was clear with a northerly wind. Snow could be seen on the mountains. The American fleet was anchored across the Valcour Channel from near Bluff Point to the New York shore. There were 500 non-sailors in this fleet. The British fleet, 700 sailors, had passed the eastern shore of Valcour Island the previous

day, sailing south. In order to attack the American fleet, the British fleet had proceeded to windward up the Valcour Channel by tacking and rowing.

The first British ship was sighted by the Americans at 8 AM. The battle commenced three hours later at 11 AM with the main forces joining battle at 12:30 PM. The battle ended at 5 PM. During the battle Arnold's flag ship "Royal Savage" was badly damaged and driven ashore on Bluff Point where it was abandoned.

After the battle the British fleet retired south and anchored in a blocking line with the eastern end of the line near Garden Island. However, during the night Arnold was able to slip away by sailing down the western shore of the Channel. On the following days in their search for the American fleet, it was reported that some British ships fired upon a rock south of Providence Island, thinking it was an American ship. That rock is now named Carleton Prize.

Eligibility: Open to all PHRF boats.

Classes:

- A: Spinnaker (full race) PHRF Handicap 99 and lower.
- B: Spinnaker (full race) PHRF Handicap 102-141.
- C: Spinnaker (full race) PHRF Handicap 144-177
- D: Spinnaker (full race) PHRF Handicap 180 and higher
- N: Non-spinnaker (maximum rated PHRF genoa)

Skippers' Meeting: None

Starting Times and Sequence:

See Page 75 for explanation of Starting Sequence. Class Flag is "White".

| Class | Flag | Warning | Preparatory | Start |
|---------------|-------|---------|-------------|-------|
| A, B, C, D, N | White | 1100 | 1101 | 1105 |

Course:

- a. Start near Carleton Prize
- b. RN 24 (Crab Island) to port
- c. Crab Island to port
- d. RN 2 (Valcour Shoal) to starboard
- e. GC 3 (in Valcour Channel) to port
- f. Garden Island to starboard
- g. RN 28 (Garden Island Ledge) to port
- h. Finish near Carleton Prize

Course length 12.25 nm

Time Limit: 1630 hours for all classes

Shortened Course: The course may be shortened to finish at any of the RN's that are marks on the course.

Scoring: All Classes will use PHRF time-on-time handicap and will be scored using The Racing Rules of Sailing for 2005-2008 ISAF Rule 89.3 and Appendix A.

Awards: Benedict Arnold Trophy to the boat with the fastest corrected time regardless of class.

2008 Lake Champlain PHRF Championship Series

Series Format:

The PHRF Committees of the Malletts Bay Boat Club, The Lake Champlain Yacht Club and the Valcour Sailing Club announce the Lake Champlain PHRF Championship. In the spirit of Lake wide racing, yachts are invited to participate in a four race series.

- A. The Royal Savage Regatta (MBBC)
- B. The Mayor's Cup (VSC)
- C. The Ladies Cup (LCYC)
- D. Results from either the Lake Champlain Race (MBBC) or the Commodore MacDonough Race (LCYC)

Eligibility:

Any yacht with a valid 2008 Lake Champlain PHRF certificate is eligible to participate in the 2008 Lake Champlain PHRF Championship.

Rules:

The rules governing the particular event as described in the sailing instructions and referenced authorities for the particular event shall govern each event that makes up the 2008 Lake Champlain PHRF Championship.

Scoring:

Scoring will be based on overall fleet position without regard to PHRF class per event (as opposed to per race in a multi-race event), counting only boats participating in the 2008 PHRF Championship Series. Fleet position will be determined in accordance with the rules of the particular event for determining fleet position (e.g. best combined finishes in a multi-race event as opposed to lowest total corrected time). Scoring will be by low point system, with each boat being scored a number of points equivalent to its overall fleet position, except that a yacht winning an event will receive three-quarters of a point.

A boat not finishing an event or any race in a multi-race event will be scored one point more than the number of series participants who finished an event or who finished all races in a multi-race event. Boats not starting a race in a multi race event will be scored two points more than the number of boats finishing an event or all races in a multi-race event.

Ties will be broken in the following manner:

- (a) the first tie-breaker will be head-to-head corrected time finishes: which boat beat the other more often;
- (b) the second tie-breaker will be the lowest aggregate corrected time of races in which the tied boats sailed against each other.
- (c) there will be no additional tiebreakers.

There will be no throw outs races, although only one of the overnight races (Lake Champlain Race or long course MacDonough Race) will be counted in a yacht's series score. A boat need only participate in one of the overnight races (Lake Champlain Race or long course MacDonough Race) to be eligible for the series championship. A boat must participate in one of the above overnight races to be

eligible for the series championship.

Championship:

The boat with the least accumulated points as a result of the series will be the 2008 Lake Champlain PHRF Champion. The championship boat will have its name inscribed on the Griswold Cannon Trophy which will be maintained at the Shelburne Shipyard. Other trophies for other finishers may also be awarded.

Past Winners of Awards & Races

FREE-FOR-ALL RACE

1937 "Sea Call" - H.M. Proctor
1938 "Beaver" - G.D. Stephens
1939 "Beaver" - G.D. Stephens
1940 "Elizabeth" - W.R. Christopherson
1941 "Elizabeth" - W.R. Christopherson
1946 "Saratoga" - W.R. Christopherson
1947 "Scamper II" - B. Stratton
1948 "Scamper II" - B. Stratton
1949 "Eleanor" - Camp Red Cloud
1950 "Kid" - Ted Brooks
1951 "Kid" - Ted Brooks
1952 "Kid" - Ted Brooks
1953 "Kid" - Ted Brooks
1956 "Clara Brown" - W.R. Christopherson
1957 "Eleanor" - Camp Red Cloud
1958 "Corlaer" - W.W. Freeman
1959 "Caravelle"-Robert and Jack Shearer
1963 "Princess" - J. Hoyt
1964 "Clara Brown" - Philip Davis
1965 "Venture"-Fred Allen / Ben Schweyer
1966 "Mademoiselle" - Mark Shearer
1967 "New World" - Philip Davis
1968 "Starkeeper" - James Wright

STAR FLEET TROPHY

1967 Roy Neuer
1968 Al Duval
1969 Alden Bryan
1970 Alden Bryan
1971 Alden Bryan
1972 Alden Bryan

FREE PRESS TROPHY

1966 "Saucy Fox" - W. Wiese
1967 "Mademoiselle"-Jack / Mark Shearer
1968 "Mame" - Steele Griswold
1969 "Saucy Fox" - W. Wiese
1970 "Saucy Fox" - W. Wiese
1971 "Escapade" - Harry Halsted
1972 - tie "Snow Goose" - Fred Allen
"Mable" - Steele Griswold
1973 "Escapade" - Harry Halsted
1974 "Snow Goose" - Fred Allen
1975 "Snow Goose" - Fred Allen
1976 "Mame" - Steele Griswold
1977 "Coyote" - Clifford/King
1978 "Snow Goose" - Fred Allen
1979 "Snow Goose" - Fred Allen
1980 "Escapade" - Harry Halsted
1981 Mame

1982 Shenanigan
1983 Mame
1984 Horse Feathers
1985 Mame
1986 Peregrine
1987 Peregrine
1988 Showtime
1989 Golden Dazy
1990 Golden Dazy
1991 Showtime
1992 Mohawk Warrior
1993 Peregrine
1994 Mohawk Warrior
1995 Mohawk Warrior
1996 Lionheart
1997 Lionheart
1998 Lionheart
1999 Frankly Scarlett
2000 Gingerbread Man
2001 Gingerbread Man
2002 Imagine...

LONG DISTANCE RACE

1940 "Eleanor" - Camp Red Cloud
1941 "Elizabeth" - W.R. Christopherson
1946 "Venture" - W.W. Freeman
1947 "Saratoga" - W.R. Christopherson
1948 "Saratoga" - W.R. Christopherson
1949 "Saratoga" - W.R. Christopherson
1950 "Gesture" - W.W. Freeman
1951 "Ginger" - Ethan A. Sims
1952 "Gesture" - W.W. Freeman
1953 "Gesture" - W.W. Freeman
1954 "Charybdis" - D.A. Stephens
1955 "Charybdis" - D.A. Stephens
1956 "Gesture" - W.W. Freeman
1957 "Clara Brown" - W.R. Christopherson
1958 "Corlaer" - W.W. Freeman
1959 "Corlaer" - W.W. Freeman
1960 "Luna" - David H. Gray
1961 "Quinta" - Philip Davis
1962 "Corlaer" - W.W. Freeman
1963 "West Wind" - L.K. Wetzel
1964 "Quotient" - G. Little
1965 "New World" - Philip Davis
1966 "Saucy Fox" - W. Wiese
1967 "New World II" - Philip Davis
1968 "Mademoiselle" - Jack Shearer
1969 "New World" - Philip Davis
1970 "Carol-E" - Jim Reed
1971 "Escapade" - Harry Halsted
1972 "Easy Rider" - Jan Rozendaal
1973 "Escapade" - Harry Halsted
1974 "Vamp" - Todd Murphy
1975 "Escapade" - Harry Halsted
1976 "Wiki Wiki" - Harry Walcoff
1977 "Mame" - Steele Giswold

1978 "Orange Crush" - Pete Clifford
 1979 "Synergy" - Bruce Hill
 1981 "Yellowjacket" - Jim Corcoran
 1982 "Leprechan" - Jeff Allen
 1983 "Neverland" - Helmut Besser
 1984 "Freya" - Vern Emerson
 1985 "Snow Goose" - Ted Teffner
 1986 "Getaway" - Bob Dion
 1987 "Wild Thing" Carr / Rowland
 1988 "Hawke" - Glenn Parker
 1990 "El Rojo" - Glenn Parker
 1991 "Flirt" - Helmut Besser
 1992 "Teal" - John Wood
 1993 "Espada" - Dave Ellis
 1994 "Valkyrie" - Dick Villamil
 1995 "Flirt" - Helmut Besser
 1996 "Espada" - Dave Ellis
 1997 "El Rojo" - Glenn Parker
 1997 "Deserved" John Rivolta

LAKE CHAMPLAIN RACE

1956 "Gesture" - W.W. Freeman
 1957 "Merry Chase" - George & Barbara Chase
 1958 "Aeolus II" - David Partridge
 1960 "Aeolus II" - David Partridge
 1961 "Quinta" - Philip Davis
 1962 "Corlaer" - W.W. Freeman
 1963 "Enterprise" - M. Allen, J. Shearer
 1964 "Clara Brown" - Philip Davis
 1965 "New World" - Philip Davis
 1966 "Saucy Fox" - W. Wiese
 1967 "Saucy Fox" - W. Wiese
 1968 "New World II" - Philip Davis
 1969 "New World" - Philip Davis
 1970 "Saucy Fox" - W. Wiese
 1971 "New World" - Philip Davis
 1972 "Snow Goose" - Fred Allen
 1973 "Snow Goose" - Fred Allen
 1974 "Snow Goose" - Fred Allen
 1975 "Semi-Tough" - Clifford/ Brush
 1976 "Escapade" - Harry Halsted
 1977 "Escapade" - Harry Halsted
 1978 "Synergy" - Bruce Hill
 1979 "Abraxax" - Mark Shearer
 1980 "Golden Dazy" - Bruce Hill
 1981 "Wiki Wiki" - Paul Graves
 1982 "Illusion" - Al Hobart/Rod Carr
 1983 "Grand Cru" - Bud Sibley
 1984 "Brandywine" - C. Brush/Adams
 1985 "Peregrine" - Don Brush/Fritz Horton
 1986 "Full Tilt" - Dick Spurlock
 1987 "Peregrine" - Don Brush/Fritz Horton
 1988 "Adrenalin Again" - Beaudin Family
 1989 "Golden Dazy" - Bruce Hill
 1990 "Demon in Disguise" - Chris Morgan
 1991 "Centauri" - Rick Stevens

1992 "Golden Dazy" - Bruce Hill
 1993 "Golden Dazy" - Jeff Hill
 1994 "Golden Dazy" - Jeff Hill
 1995 "Bark Ode" - Harold Browne
 1996 "Firewater" - Mark Grosby
 1997 "Bark Ode" - Browne/Gardner
 1998 "Bark Ode" - Browne
 1999 "Bark Ode" - Browne
 2000 "Gingerbread Man" - Chris Morgan
 2001 "Gingerbread Man" - Chris Morgan
 2002 "Surgeon General's Warning" - Rod Carr / Bob Fardelmann
 2003 "aja" Peter Abele
 2004 "K2" Luis Gonzalez
 2005 "K2" Luis Gonzalez
 2006 "Gingerbread Man" - Chris Morgan
 2007 "Last Kid Picked" Alan Ouellette

ROYAL SAVAGE RACE

1960 "Kid" - Ted Brooks
 1961 "Stratus" - Fred Senftleber
 1962 "Venture" - Fred Allen/Ben Schweyer
 1963 "West Wind" - L.K. Wetzel
 1964 "Venture" - Fred Allen/Ben Schweyer
 1965 "New World" - Philip Davis
 1966 "Carol-E" - Jim Reed
 1967 "Venture" - Fred Allen
 1968 "Mame" - Steele Griswold
 1969 "Escapade" - Harry Halsted
 1970 "Escapade" - Harry Halsted
 1971 "New World" - Philip Davis
 1972 "Escapade" - Harry Halsted
 1973 "Easy Rider" - Jan Rozendaal
 1974 "Mame" - Steele Griswold
 1975 "Mame" - Steele Griswold
 1976 "Mame" - Steele Griswold
 1977 "Mame" - Steele Griswold
 1978 "Mame" - Steele Griswold
 1979 "Escapade" - Harry Halsted
 1980 "Vagary II" - Dick Villamil
 1981 "Hobbit Hole" - Peter Cottrell
 1982 "Illusion" - Al Hobart/Rod Carr
 1983 "Golden Dazy" - Bruce Hill
 1984 "Frankly Scarlett" - Bob Kaphan
 1985 "Espada" - Dave Ellis
 1986 "Sly" - Marcel Beaudin
 1987 "Peregrine" - Don Brush/Fritz Horton
 1988 "Hot Toddy" - Jim Connors
 1989 "Coyote Ugly" - John Landry / John Reynolds
 1990 "Majic" - Randy Kruger
 1991 "Toad's Wild Ride" - Jim Finch & Marcy Milton
 1992 "Coyote Ugly" - John Landry / John Reynolds
 1993 "Downtown" - John Reynolds
 1994 "Full Tilt" - Richard Spurlock

Past Winners

1995 "Mohawk Warrior" - Dave Gorman
1996 "Lionheart" - Norm Alpert
1997 "Lionheart" - Norm Alpert
1998 "Toads Wild Ride" - Finch/Milton
1999 "Toads Wild Ride" - Finch/Milton
2000 "Real Escape" - Don Duley
2001 "Gingerbread Man" - Chris Morgan
2002 "Knockout" Gene Cloutier
2003 "K2" - Luis Gonzalez
2004 "Image" Carr / Fardelmann
2005 "Last Kid Picked" Alan Ouellette
2006 "K2" - Luis Gonzalez
2007 "Last Kid Picked" Alan Ouellette

TED BROOKS TROPHY

1968 "Mame" - Steele Griswold
1969 "New World" - Philip Davis
1970 "Escapade" - Harry Halsted
1971 "New World" - Philip Davis
1972 "Escapade" - Harry Halsted
1973 "Gusto" - Morty Kaufman
1974 "Escapade" - Harry Halsted
1975 "Mame" - Steele Griswold
1976 "Mame" - Steele Griswold
1977 "Mame" - Steele Griswold
1978 "Mame" - Steele Griswold
1979 "Siren Song" - H. Wakem
1980 "Golden Dazy" - Bruce Hill
1981 "Golden Dazy" - Bruce Hill
1982 "Golden Dazy" - Bruce Hill
1983 "Golden Dazy" - Bruce Hill
1984 "Frankly Scarlett" - Bob Kaphan
1985 "Spellbound" - Jay Trumper
1986 "Adrenalin" - Tim McKegey
1987 "Peregrine" - Don Brush/Fritz Horton
1988 "Sound Wave" - Jay Marshall
1989 "Coyote Ugly" - Landry/ Reynolds
1990 "Majic" - Randy Kruger
1991 "Leprechaun" - Jeff Allen
1992 "Coyote Ugly" - Landry/ Reynolds
1993 "Peregrine" - Fritz Horton/Don Brush
1994 "Swan Song" - Allen Johnson
1995 "Fawn Leibowitz" - Al Hobart
1996 "Maverick" - Don Rathbone
1997 "Ragtime" - John O'Rourke
1998 "Lionheart" - Norm Alpert
1999 "Frankly Scarlet" Dave Powlison
2000 "Gingerbread Man" - Chris Morgan
2001 "Bark Ode" -Harold Browne
2002 "Swish Ca Bob" - Bob Drawgaugh
2003 "Ice Cube" -Mike Quaid
2004 "Last Kid Picked" Alan Ouellette
2005 "K2" - Luis Gonzalez
2006 "Ice Cube" -Mike Quaid
2007 "K2" - Luis Gonzalez

COFFEE POT

1960 "Corlaer" - W.W. Freeman
1961 "Luna" - David H. Gray
1962 "Corlaer" - W.W. Freeman
1963 "Mon Jac" - Allen and Shearer
1964 "Corlaer" - W.W. Freeman
1965 "Reggio" - S. Lee
1966 "Mademoiselle" - Jack Shearer
1967 "Saint" - Steele Griswold
1968 "Hysteria" - Fred Wuensch
1969 "Mame" - Steele Griswold
1970 "Starkeeper" - J. Wright
1972 "Escapade" - Harry Halsted
1973 "Sea Gipsy" - Gib Smith
1974 "Snow Goose" - Fred Allen
1975 "Hesperia" - Ken Wolvington
1976 "Mame" - Steele Griswold
1977 "Coquette" - Gordon Anger
1978 "Sea Gipsy" - Gib Smith
1979 "Espada" - Dave Ellis
1980 "Slingshot" - Bob Whyte
1981 "Snow Goose" - Fred Allen
1982 "Shenanigan" - Tom Raub
1983 "Chaosarou" - Rob McDowell
1984 "Illusion" - Al Hobart / Rod Carr
1985 "Peregrine" - Don Brush/Fritz Horton
1986 "Illusion" - Al Hobart / Rod Carr
1987 "Slippery" - Al Hobart / Al & Lisa
Russell
1988 "Peregine" - Don Brush / Fritz Horton
1989 "Lightshow" - Gerry Davis/Dave
Robbins
1990 "Coyote Ugly" -John Reynolds / John
Landry
1991 "Full Tilt" - Dick Spurlock
1992 "Ricochet" - Dave Powlison
1993 "Swan Song" - Al Johnson
1994 "Leprechaun" - Jeff Allen
1995 "Full Tilt II" - Richard Spurlock
1996 "Full Tilt II" - Richard Spurlock
1997 "Phantom" - Rod Carr
1998 "Full Tilt II" - Richard Spurlock
1999 "Phantom" - Rod Carr
2000 "Bark Ode" - Browne / Gardner
2001 "Toad's Wild Ride" - Finch / Milton
2002 "Bark Ode" - Browne / Gardner"
2003 "Last Kid Picked" Alan Ouellette
2004 "Celerity" - Alex Nimick
2005 "Bark Ode" -Browne/Gardner
2006 "Dog House" - Harold Browne
2007 "K2" - Luis Gonzalez

CORRECTIONS CUP

1998 "High Noon" - Williams
1999 "High Noon" - Williams
2000 "C-Jam Blues" - Dickerson
2001 "Alacrity" - Besse
2002 "Swish Ca Bob" - Bob Drawbaugh

2003 "Lift Ticket" – Pratt
 2004 "Lift Ticket" – Pratt
 2005 "Swish Ca Bob" - Bob Drawbaugh
 2006 "C Jam Blues" - Charly Dickerson
 2007 "Bolero" - Dickerson

BENEDICT ARNOLD RACE

1968 "Saucy Fox" - W. Wiese
 1969 "Mame" - Steele Griswold
 1970 "Saucy Fox" - W. Wiese
 1971 "Escapade" - Harry Halsted
 1972 "Escapade" - Harry Halsted
 1973 "Mame" - Steele Griswold
 1974 "Mame" - Steele Griswold
 1975 "Snow Goose" - Fred Allen
 1976 "Snow Goose" - Fred Allen
 1977 "Mame" - Steele Griswold
 1978 "Espada" - Dave Ellis
 1979 "Espada" - Dave Ellis
 1980 "Yellowjacket" - Jim Corcoran
 1981 "Leprechaun" - Don O'Brien
 1982 "Neverland" - Helmut Besser
 1983 "Peregrine" - Don Brush/Bob Whyte
 1984 "Peregrine" - Don Brush/Bob Whyte
 1985 "Peregrine" - Don Brush/Fritz Horton
 1986 "Pterodactyl" - Chuck Bond
 1987 "Espada" - Dave Ellis
 1988 "Bar Code" -Jim Finch/Mark Gardner
 1989 "High Priority" - Joe Woods
 1990 "Espada" - Dave Ellis
 1991 "Black Widow" - Erika Stuart
 1992 "Bark Ode" -Harold Browne/ Mark Gardner
 1993 "Leprechaun" - Jeff Allen
 1994 "Toad's Wild Ride" -Jim Finch & Marcy Milton
 1995 "Results" - Ken Signorello
 1996 "Espada" - Dave Ellis
 1997 "Leprechaun" - Jeff Allen
 1998 "Goodwood" - Todd Cox
 1999 "Moostaken Identity" - Marty Olsen
 2000 "Moostaken Identity" - Marty Olsen
 2001 "Goodwood" - Todd Cox
 2002 "Last Kid Picked" - Alan Ouellette
 2003 "Bark Ode" Gardner/Browne
 2004 "Last Kid Picked" - Alan Ouellette
 2005 "Bark Ode" Gardner/Browne
 2006 "Imagine" - Fardelmann / Carr
 2007 "Imagine" - Fardelmann / Carr

CHASE TROPHY

1964 Laure A. Shearer
 1965 Michele Ferland
 1966 Laure A. Shearer
 1967 Michele Ferland

1968 Olive Krogman
 1969 Olive Krogman
 1970 Mary Griswold
 1972 Olive Krogman
 1973 Candy Anger
 1975 Ann Brush
 1976 Belinda Emerson
 1977 Ann Brush
 1979 Ann Brush
 1980 Kathleen Corcoran
 1981 Pat Cottrell
 1982 Linda Raub
 1983 Belinda Emerson
 1985 Janice Lange
 1986 Ann Brush
 1990 Joan Shannon
 1991 Joan Shannon
 1992 Sally Sharp
 1993 Deb Hopkins
 1994 Sally Sharp

CHIOTT CUP

1963 Steele T. Griswold (Flying Scot)
 1964 Jeffrey A. Shearer (Sunfish)
 1965 Laure Shearer (Flying Scot)
 1966 J.D. Clewley (Lightning)
 1967 Roy Neuer (Star)
 1968 Lewis Wetzel (Cruising Class)
 1969 Vern Emerson (Lightning)
 1970 Dick Miller (Flying Scot)
 1971 Alden Bryan (Star)
 1972 Alden Bryan (Star)
 1973 Alden Bryan (Star)
 1974 Don Brush (Lightning)
 1976 Bill Dunnington (Lightning)
 1977 Don Brush (Lightning)
 1978 Don Brush (Lightning)
 1979 Chris Morgan (Laser)
 1980 Al Hobart (J-24)
 1981 Don Brush (Lightning)
 1982 Don Brush (J-24)
 1983 Don Brush (Lightning)
 1984 Al Hobart/Rod Carr (J-24)
 1985 Dave Powlison (Laser)
 1986 Peter Hall (Lightning)
 1987 Al Hobart/Al & Lisa Russell (J-24)
 1988 Todd Wulfson (Laser)
 1989 Bill Fastiggi (Lightning)
 1990 Tim McKegney (Laser)
 1991 Rick Fastiggi (Lightning)
 1992 John Reynolds/John Landry (J-24)
 1993 Dave Powlison (Laser)
 1994 John & Leslie Reynolds (J-24)
 1995 Sean Carroll (Lightning)
 1996 Boynton, Castle, Lampman (J-24)
 1997 Bill Fastiggi (Lightning)
 1998 Al Hobart (J-24)

Past Winners

1999 Rod Carr (J-80)
2000 Rod Carr (J-80)
2001 Al Hobart (J-24)
2002 Bill Fastiggi (Lightning)
2003 Al Hobart (J-24)
2004 Luczynski (Laser)
2005 USA3225 Reindel (J-24)
2006 Bretton Gardner (Lightning)
2007 Al Hobart (J-24)

SUMMER SERIES Lightning

1977 A: Dick Fastiggi
B: Bill Dunnington
1978 A: Dave Little
B: Vern Emerson
1979 A: Don Brush
B: Ed Ziemer
1980 A: Don Brush
B: John Hughes
1981 A: Ann Brush
B: John Hughes
1982 A: John Hughes
B: John Hughes
1983 A: John Hughes
B: Kurt Kling
1984 Kurt Kling
1985 Peter Hubbard
1986 Dick Fastiggi
1987 Don Brush
1988 Bill Fastiggi
1989 Bill Fastiggi
1990 Bill Fastiggi
1991 Janice Lange
1992 Don Brush
1993 Janice Lange
1994 Don & Ann Brush
1995 Bill Fastiggi
1996 Bill Fastiggi
1997 Bill Fastiggi
1998 Kurt Kling
1999 Dave Gorman
2000 Gardner Family
2001 Bill Fastiggi
2002 Karl-Erik Johnson
2003 Patrick Zachary
2004 Not Awarded
2005 Bill Fastiggi
Laser
1977 A: Donny Weaver
B: Donny Weaver
1978 A: Donny Weaver
B: Chris Morgan
1979 A: Donny Weaver
B: Rick Leonard
1980 A: Donny Weaver
B: Martin Lurie

1981 A: Tris Coffin
B: Roy Watson III
1982 Brian Hughes
1983 Dave Powlison
1984 Tim McKegney
1985 Dave Powlison
1986 Dave Powlison
1987 Bill Fastiggi
1988 Todd Wulfson
1989 Todd Wulfson
1990 Tris Coffin
1991 Todd Wulfson
1992 Dave Powlison
1993 Dave Powlison
1994 Dave Powlison
1995 Al Russel
1996 Dave Powlison
2002 Ken Signorello
2003 Chris Doyle
2006 Mark Gardner
2007 Patrick Zachary

J-24

1981 A: "This Side Up" - J. Reynolds
B: "Sly" - M. Beaudin
1982 A: "Sly" - M. Beaudin
B: "Sly" - M. Beaudin
1983 A: "Sly" - M. Beaudin
B: "Sly" - M. Beaudin
1984 "This Side Up" - J. Reynolds
1985 "Sly" - M. Beaudin
1986 "Sly" - M. Beaudin
1987 "Slippery" - Al Hobart/Al Russell
2002 "Ice Cube" Mike Quaid
2003 "Last Kid Picked" Alan Ouellette

J24 FLEET 23 CHAMPIONSHIP

1979 T Crow
1980 A Hobart
1981 Beaudins
1982 A. Hobart/R. Carr
1983 Beaudin & Sons
1984 Beaudin & Sons
1985 Beaudin & Sons
1986 Beaudin & Sons
1987 Slippery
1988 Slippery
1990 Slippery
1995 A. Hobart
2002 Ice Cube
2003 Last Kid Picked
2004 Last Kid Picked
2005 Ice Cube
2006 Fawn Liebowitz – Hobart
2007 Last Kid Picked

SINGLE HANDED RACE

1978 "Abraxas" - Mark Shearer
 1979 "Abraxas" - Mark Shearer
 1980 "Lysistrata" - Glenn Parker
 1981 "Pamalu" - Ted Teffner
 1982 "Shenanigan" - Tommy Raub
 1983 "Doctor's Orders" - Chris Pilcher
 1984 "Shenanigan" - Tommy Raub
 1985 "Chinook" - Harold Browne
 1986 "Sly" - Jeb Beaudin

DOUBLE HANDED RACE

1987 (Tie) "Shenanigan" - Tom & Tom Raub
 "Snow Goose" - Ted & Jake Teffner
 1989 "No Illusion" Bill & Dick Fastiggi
 1990 "Demon in Disguise" Morgan & B. Limoge
 1992 "Fly Boy" - M. Dressell & J. Marshall
 1993 "Nike" - Mike Jackson
 1994 "C Jam Blues" - C. Dickerson & M. Hooper
 1995 "C Jam Blues" - C. Dickerson & M. Hooper
 1996 "C Jam Blues" - C. Dickerson & M. Hooper
 1997 "Phantom" - R. Carr & R. Fardelmann
 1998 "Moostaken Identity" Marty Olsen
 1999 "High Noon" Tom Noone
 2000 "High Noon" Tom Noone
 2001 "Toad's Wild Ride" Finch/Milton
 2002 "Moosetaken Identity" Marty Olsen
 2003 "Imagine" - Fardleman/Carr
 2004 "Slippery" Allan Russell
 2005 "Last Kid Picked" - Alan Ouellette
 2006 "Last Kid Picked" - Alan Ouellette
 2007 "Imagine" - Fardelmann/Carr

ETHAN ALLEN RACE

1982 "Pamalu" - Ted Teffner
 1983 "Illusion" - Rod Carr
 1984 "Chinook" - Harold Browne
 1985 "Doctor's Orders" - Dave Pilcher
 1986 "Chinook" - Harold Browne
 1987 "Sun Spot" - Joe Woods
 1988 "Hesperia" - Ken Wolvington
 1989 "Chinook" - Harold Browne
 1990 "High Priority" - Joe Woods
 1991 "Moose-A-Beam" - Marty Olsen
 1992 "Moose-A-Beam" - Marty Olsen
 1993 "Toad's Wild Ride" Jim Finch & Marcy Milton
 1994 "Moosetaken Identity" -Marty Olsen
 1995 "C JAM Blues" - Charly Dickerson
 1996 "Espada" - Dave Ellis
 1997 "Espada" - Dave Ellis
 1998 "Results" - Ken Signorello

1999 "Lift Ticket" - Dan Pratt
 2000 "Moosetaken Identity" - Marty Olsen
 2001 "Celerity" - Alec Nimick
 2002 "Last Kid Picked" - Alan Ouellette
 2003 "Imagine" - Fardelmann/Carr
 2004 "Last Kid Picked" - Alan Ouellette
 2005 "Last Kid Picked" - Alan Ouellette
 2006 "Black Rose" - Ed Bombard
 2007 "Moosetaken Identity" - Marty Olsen

CANNON TROPHY

1982 "Havoc" - Jeff Dinse
 1983 "Peregrine" - Bob Whyte/Don Brush
 1984 "Mame" - Steele Griswold
 1985 "Mame" - Steele Griswold
 1986 "Peregrine" - Don Brush/Fritz Horton
 1987 "Golden Dazy" - Bruce Hill
 1988 "Showtime" - Don O'Brien
 1989 "Golden Dazy" - Bruce Hill
 1990 "Golden Dazy" - Bruce Hill
 1991 "Showtime" - Don O'Brien
 1992 "Coyote Ugly" - J. Reynolds/J. Landry
 1993 "Peregrine" - F. Horton/D. Brush
 1994 "Mohawk Warrior" - Dave Gorman
 1995 "Peregrine" - Don Brush/Fritz Horton
 1996 "Lionheart" - Norm Alpert
 1997 "Lionheart" - Norm Alpert
 1998 "Lionheart" - Norm Alpert
 2004 "Peregrine" - Horton/Bond
 2005 "K2" - Luis Gonzalez
 2006 "K2" - Luis Gonzalez
 2007 "Last Kid Picked" - Alan Ouellette

GOOSE TROPHY

1992 "Flirt" - Helmut Besser
 1993 "Toad's Wild Ride" - J. Finch/M. Milton
 1994 "Swan Song" - Al Johnson
 1995 "Sto Lat II" - Tony Lamb
 1996 "Legacy" - Bob Goodwin
 1997 "Toad's Wild Ride" - M. Milton/J. Finch
 1998 "Legacy" - Bob Goodwin

CORLAER TROPHY

1983 "Espada" - Dave Ellis
 1984 "Espada" - Dave Ellis
 1985 "Espada" - Dave Ellis
 1986 "Valkyrie" - Dick Villamil
 1987 "Swan Song" - Al Johnson
 1988 "Hot Toddy" - Jim Connors
 1989 "Carina" - Ed Ziemer
 1991 "Carina" - Ed Ziemer
 1992 "Carina" - Ed Ziemer
 1995 "Carina" - Ed Ziemer

Past Winners

- 1996 "Carina" - Ed Ziemer
1997 "Impulsive" - Michael Ray
1998 "Carina" - Ed Ziemer
1999 "Carina" - Ed Ziemer
- MIDWEEK SERIES**
- 1977 "First Fiddle" - Allen Johnson
1978 "Doctor's Orders" - Dave Pilcher
1979 "Lysistrata" - Glenn Parker
1980 "Zoom" - Ed Ziemer
1981 A - "Shenanigan" - Tom Raub
B - "Sitzmark" - Dick Dodge
C - "Zoom" - Ed Ziemer
1982 A - "Espada" - Dave Ellis
B - "Sitzmark" - Dick Dodge
C - "Zoom" - Ed Ziemer
D - "Shenanigan" - Tom Raub
1983 A - "Sun Spot" - Joe Woods
B - "Kehoa" - Fred Aliesky
C - "Zoom" - Ed Ziemer
D - "Shenanigan" - Tom Raub
1984 A - "Sun Spot" - Joe Woods
C - "Zoom" - Ed Ziemer
D - "Shenanigan" - Tom Raub
1985 A - "Sunspot" - Joe Woods
B - "Airborne" - Bob Gobin
C - "Zoom" - Ed Ziemer
D - "Illusion" - Rod Carr/Al Hobart
1986 A - "Sunspot" - Joe Woods
C - "Zoom" - Ed Ziemer
D - "Fat Cat II" - Don Weaver
1987 A - "Sun Spot" - Joe Woods
B - "Fortune Hunter" - D. Schwartz
C - "Zoom" - Ed Ziemer
D - "Bar Code" - Finch/Gardner
1988 A - "Panache" - Jon Aswad
B - "Halycon" - Dave Lamphere
C - "Zoom" - Ed Ziemer
D - "Bar Code" - Finch/ Gardner
1989 A - "Panache" - Jon Aswad
C - "Zoom" - Ed Ziemer
D - "Majic" - Randy Kruger
E - "Full Tilt" - Dick Spurlock
1990 A - "Ricochet" - Dave Powlison
B - "Fortune Hunter" - D. Schwartz
C - "Zoom" - Ed Ziemer
D - "Slippery" - Russell/Hobart
E - "Coyote Ugly" - Landry/Reynolds
1991 A - "Panache" - Jon Aswad
B - "Fortune Hunter" - D. Schwartz
C - "Zoom" - Ed Ziemer
D - "Slippery" - Russell/Hobart
E - "Ricochet" - Dave Powlison
F - "Bark Ode" - Browne/ Gardner
1992 A - "Panache" - Jon Aswad
B - "Moirra E. III" - Randy Whitney
C - "Zoom" - Ed Ziemer
D - "Fly Boy" - Dressell/Marshall
E - "Ricochet" - Dave Powlison
F - "Bark Ode" - Browne/ Gardner
1993 A - "Swan Song" - Al Johnson
B - "Moirra E. III" - Randy Whitney
C - "Zoom" - Ed Ziemer
D - "Fly Boy" - Dressell/Marshall
E - "Legacy" - Bob Goodwin
F - "Bark Ode" - Browne/ Gardner
1994 A - "Swan Song" - Al Johnson
B - "Victory" - Dick Villamil
C - "Zoom" - Ed Ziemer
D - "High Noon" - Tom Noone
E - "Toad's Wild Ride" - Finch/Milton
F - "Full Tilt" - Dick Spurlock
1995 A - "Celerity" - Alex Nimick
B - "Espada" - Dave Ellis
C - "Zoom" - Ed Ziemer
D - "High Noon" - Tom Noone
E - "Full Tilt" - Dick Spurlock "Bark Ode" - Gardner/Browne
1996 A - "Swan Song" - Allen Johnson
B - "Espada" - David Ellis
C - "Zoom" - Ed Ziemer
D - "Results" - Ken Signorello
E - "Bark Ode" - Browne/Gardner
1997 B - "Leprechaun" - Jeff Allen
C - "High Noon" - Tom Noone
D - "Celerity" - Alex Nimick
N - "Ninkasi" - Ed Hutchinson
L - "Deviant" - John Rivolta
1998 B - "Phantom" - Rod Carr
C - "Noone" - Tom Noone
D - "Celerity" - Al Nimick
N - "Child's Play" - John Chickanosky
L - "Zoom" - Ed Ziemer
1999 B - "Bark Ode" - Browne/Gardner
C - "Hot Chocolate" - Lampman
D - "Celerity" - Al Nimick
N - "Child's Play" - J. Chickanosky
L - "Zoom" - Ed Ziemer
2000 B - "Bark Ode" - Browne/Gardner
C - "High Noone" - Tom Noone
D - "Impulsive" - Michael Ray
N - "Indigo" - Jon & Nancy Aswad
L - "What Now" - Patrick Zachary
2001 B - "Bark Ode" - Browne/Gardner
C - "Ice Cube" - Tom Noone
D - "Swan Song" - Al Johnson
N - "Ginny Marie" - G. Couture
L - "Scallywag" - Bill Dutcher
2002 B - "Bark Ode" - Browne/Gardner
C - "Downtown" - Tom Noone
N - "Victory" Richard Villamil
L - "Zoom" Ed Ziemer

- 2003 B - "Imagine" - Fardlemann/Carr
 C - "Last Kid Picked" Ouellette
 D - "Swan Song" Al Johnson
 N - "Prime Time" Jonathon Haas
 L - "Zoom" Ed Ziemer
- 2004 A/B - "Bark Ode" Gardner/Browne
 C - "Last Kid Picked" Alan Ouellette
 D - "Impulsive" Michael Ray
 L - "Pure Insanity" T&H Ambrose
 N - "aja" Peter Abele
- 2005 A/B - "Bark Ode" Gardner/Browne
 C - "Yeti" Hamilton
 D - "Swan Song" Al Johnson
 L - "Dude... Sweet" Karl & Erik Johnson
 N - "Prime Time" Jonathon Haas
- 2006 A/B - Imagine - Carr/Fardelmann
 C - Toads Wild Ride - Milton
 D - Swan Song - Johnson
 L - Hot Flash - Gardner
 J24 - Fawn Liebowitz - Hobart
 N - Prime Time - Haas
- 2007 A/B - Imagine - Carr/Fardelmann
 C - Toads Wild Ride - Milton
 D - Swan Song - Johnson
 L - Toiao - Zachary/Bronger
 J24 - Last Kid Picked - Ouellette
 N - Victory - Villamil
- 1987 A - "Panache" - Jon Aswad
 C - "Second Wind" - Janice Lange
 D - "Wild Thing" - Rowland/Carr
- 1988 A - "Valkyrie" - Dick Villamil
 C - "Zoom" - Ed Ziemer
 D - (Tie) "Leprechaun" - Jeff Allen
 "Chinook" - Harold Browne
- 1989 A - "Espada" - Dave Ellis
 B - "Jazz" - Bob Dion
 C - "Zoom" - Ed Ziemer
 D - "High Priority" - Joe Woods
 E - "Leprechaun" - Jeff Allen
- 1990 A - "Ricochet" - Dave Powlison
 B - "Lightshow" - Gerry Davis
 C - "Zoom" - Ed Ziemer
 D - "Chinook" - Harold Browne
 E - "Leprechaun" - Jeff Allen
- 1991 A - "Ricochet" - Dave Powlison
 B - "Jazz II" - Bob Dion
 C - "Zoom" - Ed Ziemer
 F - "Flirt" - Helmut Besser
- 1992 A - "Panache" - Jon Aswad
 B - "Teal" - John Wood
 C - "Zoom" - Ed Ziemer
 Div I "Nike" - Mike Jackson
 Div II "Ricochet" - Dave Powlison
- 1993 A - "Meridian" Jon & Nancy Aswad
 B - "Victory" - Dick Villamil
 C - "Zoom" - Ed Ziemer
 Div I "Bark Ode" - Browne/ Gardner
 Div II "High Noon" - Tom Noone
- 1994 A - "Wind Song" - Janice Lang
 B - "Espada" - Dave Ellis
 Div I "Demon in Disguise" - John Harris
 Div II "Figment" - Todd Cox, Lynn Murray
- 1995 A - "Carina" - Ed Ziemer
 B - "Espada" - Dave Ellis
 C - "Second Wind" - Janis Lange
 D - "Results" - Ken Signorello
 E - "Joyride" - Bob & Robin Turnau
- 1996 A - "Windsong" - Janice Lange
 B - "Northwind II" - Bob Newton
 C - "Zoom" - Ed Ziemer
- 1997 B - "Phantom" - Rod Carr
 C - "Results" - Ken Signorello
 N - "Northwind II" - Bob Newton
 L - "White Rushin'" - Janice Lange
- 1998 B - "Phantom" - Rod Carr
 C - "SwishCaBob" - Bob Drawbaugh
 N - "Northwind" - Bob Newton
 L - "Southern Cross" - Janice Lange
- 1999 B - "Moostaken Identity" Marty Olsen
 C - "Swish Ca Bob" - Bob Drawbaugh
 D - "Impulsive" - Michael Ray
 N - "Celerity" - Nimick

FALL SERIES

- 1977 "Doctor's Orders" - Dave Pilcher
 1978 "Peppermint Patty" - Vern Emerson
 1979 "Vagary II" - Dick Villamil
 1980 Laser - Tim McKegney
 1981 A - "Wildfire" - Russ Leach
 B - "Hesperia" - Ken Wolvington
 C - "Hejira" - Gary Coryer
 1982 A - "Espada" - Dave Ellis
 B - "Sitzmark" - Dick Dodge
 C - "Hejira" - Gary Coryer
 D - "Shenanigan" - Tom Raub
 1983 A - "Alice B" - James Adams
 B - "Airborne" - Bob Gobin
 C - "Hejira" - Gary Coryer
 D - "Yellowjacket" - Jim Corcoran
 1984 A - "Espada" - Dave Ellis
 C - "Zoom" - Ed Ziemer
 D - "Shenanigan" - Tom Raub
 1985 A - "Northwind" - Bob Newton
 B - "Hallycon" - Dave Lamphere
 C - "Hejira" - Gary Coryer
 D - "Shenanigan" - Tom Raub
 1986 A - "Northwind" - Bob Newton
 C - "Once More With Feeling" - Vern Emerson
 D - "Sly" - Marcel Beaudin

Past Winners

- 2000 L - "The Big Scream" -Mark Gardner
B - "Moostaken Identity" Marty Olsen
C - "Swish Ca Bob"-Bob Drawbaugh
D - "Carina" - Ed Ziemer
N - "Celerity" - Al Nimick
- 2001 L -"Ondine" - Willem Jewett
B - "Lightshow" Gerry Davis
C - "Swish Ca Bob"-Bob Drawbaugh
N - "Celerity" - Al Nimick
L -"Scallywag" - Bill Dutcher
- 2002 B "Lift Ticket- Dan Pratt
C - "Impulsive" - Michael Ray
N - "Victory" - Richard Villamil
L - "Scallwag" - Bill Dutcher
- 2003 B - "Moosetaken Identity" - Marty Olsen
C -"Impulsive" - Mike Ray
L - "HUH!" - Bretton Gardner
N - "Ginny Marie" Gerald Couture
- 2004 B - "Moosetaken Identity" - Marty Olsen
C - "Swish Ca" Bob Bob Drawbaugh
D - "Oriol" W. Rogers
N - "Swan Song" A. Johnson
- 2005 B "Moosetaken Identity" - Marty Olsen
C - "Swish Ca Bob" Bob Drawbaugh
D - "Contact" Chuck Padula
N -"Victory" - Richard Villamil
- 2006 A/B - Imagine - Carr/Fardelmann
C - Toads Wild Ride - Milton
D - Swan Song - Johnson
L - Hot Flash - Gardner
J24 - Fawn Liebowitz - Hobart
N - Prime Time – Haas

Knotta Regatta

2007 - "Ginny Marie" Gerry Couture

J24- LATE FALL SERIES

- 2003 - "Last Kid Picked" Alan Ouellette
2004 - "Opaque" - Ray Harrington
2005 - "Last Kid Picked" Alan Ouellette
2006 - Beauty – Felis
2007 - Gloria – Fastiggi/Felis

JUNIOR SAILING AWARDS

Ferland Cup - Best Skipper

- 1985 Jason Duval
1986 Matt Kapp
1987 Holly Schwartz
1988 Chris & Greg LaChance
1989 Holly Schwartz
1990 Andy Horton
1991 Andy Horton
1992 Nick Adams & Jamie Carroll

- 1993 Sean Carroll
1994 Jeff Schwartz
1995 Jeff Templeton
1996 Jeff Templeton
1997 Jeff Templeton
1998 Jeff Templeton
1999 Erik Johnson
2000 Bretton Gardner
2001 Chad Miller
2002 Chad Miller
2003 Peter Hazelett
2004 Chad Miller
2005 Nicholas Aswad
2006 Kolby Kruger
2007 Kolby Kruger
- Colin Duval Award - Best Crew
1985 Gwynne Reynolds
1986 Chris Besser
1987 Elizabeth Cottrell
1988 Jamie Carroll & Kirsten Kapp
1989 Rick Villamil
1990 David Halstead
1991 Sean Carroll
1992 Sean Carroll & Eli Lesser-Goldsmith
1993 Jason Payea
1994 Jason Payea
1995 Justin Bayer
1996 Jessica Payea
1997 Karl Johnson
1999 Karl Johnson
2000 Kate Brush
2001 Peter Hazelett
2002 Dwight Stannard
2003 Dan Kagan
2004 Peter Hazelett
2005 Tanya Miller
2006 Sam Davison
2007 Sam Davison

T. Curley Sportsmanship Cup

- 1985 Sten Seeman
1986 Holly Schwartz
1987 Rick Villamil
1988 Nick Rosner
1989 Brian Hynes
1990 Holly Schwartz
1991 Nick Adams
1992 Greg Smith
1993 Jeff Schwartz
1994 Robert Mackey
1995 Jessica Payea
1996 Rob Mackey
1997 Bretton Gardner
2001 Tanya Miller
2002 Peter Hazelett
2003 Max Far

2004 Nicholas Aswad
 2005 Samuel Davison
 2006 AJ Stephens
 2007 Max Duquette

Most Improved Award

1985 Tom Helfrich
 1986 Jamie Carroll
 1987 Dave Halstead
 1988 Greg Smith
 1989 Greg LaChance
 1990 Nick Adams
 1992 Sean Carroll
 1993 Tristen Jensvold
 1994 Jeff Templeton
 1995 Andrew Sadowski
 1996 Adam Clavelle
 1997 Eric Johnson
 1999 Bretton Gardner
 2002 Nick Aswad
 2003 Kolby Kruger
 2004 Daniel Kagan
 2005 Roxanne Powell
 2006 Riley Kruger
 2007 Sandra Groening

Race Week

1990 Andy Horton & Mike Allen
 1991 Andy Horton & Karif Martin
 1992 Nick Adams & Sean Carroll
 1993 Sean Carroll & Jason Payea
 1994 Jeff Schwartz & Jason Payea
 1995 Jeff Templeton & Jessica Payea
 1996 Jeff Templeton & Jessica Payea
 1997 Jeff Templeton & Bretton Gardner
 1998 Jeff Tempelton & Kate Brush
 1999 Erik & Karl Johnson
 2000 Bretton Gardner & Christine Toronello

CHRISTOPHERSON TROPHY

(Yankee)

1965 John Shearer
 1966 F. Allen
 1967 F. Allen

TOP SCOT TROPHY (Flying Scot)

1966 D. Griswold
 1967 D. Little
 1968 D. Little
 1969 D. Little
 1970 D. Miller
 1971 D. Miller
 1972 D. Miller

BOB SIDLE TROPHY (Lightning)

1966 Vern Emerson
 1967 Vern Emerson

1968 Vern Emerson
 1969 Vern Emerson
 1970 Vern Emerson
 1971 Vern Emerson
 1972 Vern Emerson
 1973 Vern Emerson
 1974 Bill Dunnington
 1975 Vern Emerson
 1976 Bill Dunnington
 1977 Vern Emerson
 1978 Bill Dunnington
 1979 Don Brush
 1980 Peter Hubbard
 1981 Ann Brush
 1982 Kurt Kling
 1983 Dick Fastiggi
 1984 Kurt Kling
 1985 Peter Hubbard
 1986 Dick Fastiggi
 1987 Don Brush
 1988 Bill Fastiggi
 1989 Bill Fastiggi
 1990 Bill Fastiggi
 1991 Janice Lange
 1992 Don Brush
 1993 Janice Lange
 1994 Don & Ann Brush
 1995 Bill Fastiggi
 1996 Bill Fastiggi
 1997 Bill Fastiggi
 1998 Kurt Kling
 1999 Dave Gorman
 2000 The Gardner Family
 2001 Bill Fastiggi
 2002 Erik and Karl Johnson
 2003 Patrick Zachary
 2004 Not Awarded
 2005 Bill Fastiggi
 2006 Mark Gardner
 2007 Patrick Zachary

EMERSON TROPHY (Lightning)

1970 Kay Barron
 1971 Paul Jordon
 1972 Malcolm Appleton
 1973 Dick Fastiggi
 1974 Ken Wolvington
 1975 Bill Dunnington
 1976 Don Brush
 1977 Janice Lange
 1978 Dave Little
 1979 Barb Emerson & Jean Wolvington
 1980 Chuck Leonard & Family
 1981 John & Eve Hughes
 1982 John & Eve Hughes
 1983 Stan White
 1984 Dick Fastiggi

Past Winners

1986 Ed Ziemer
1987 Don Brush
1988 Belinda Emerson
1989 Bill Fastiggi
1990 Janice Lange
1991 Dick Fastiggi
1992 Bill Fastiggi
1993 Mike Jackson
1994 Bill Fastiggi
1995 Dick Fastiggi
1996 Skip McClellan
1997 Ann Brush
1999 Charly Dickerson
2000 Patrick Zachary
2001 All MBBC Members
2002 Mark Gardner
2003 Mark Gardner

MOOSEHEAD TROPHY

1969 Ed Willard
1970 Steele Griswold
1971 Ken Wolvington
1972 Steele Griswold
1973 Dick Fastiggi
1974 Morty Kaufman
1975 Steele Griswold
1976 Bill Dunnington
1977 Gordon Anger
1978 Bob Young
1979 Don Fisher
1980 Randy Rowland
1981 Glenn Parker
1982 James Adams
1983 Dave Ellis
1984 Chris Pilcher
1985 Dan Pratt
1986 Pat Cottrell
1987 Tom Raub
1988 Don Brush
1989 Bill Cimonetti
1990 Bill Fastiggi
1991 Jim Finch
1992 Mark Gardner
1993 LCYC Regatta Committee
1994 Harold Browne
1995 Marty Olsen
1996 Jon & Nancy Aswad
1997 Jon Aswad
1998 Linda and Nile Schneider
1999 Mark Gardner
2000 Mark Gardner
2001 Gerald Duval and Steve Payea
2002 Gerald Duval
2003 Ed Ziemer
2004 Mark Gardner
2005 Bruce Foshay (as Master)
2006 Rod Carr

2007 Bill Fastiggi and Bretton Gardner

BEST FRIENDS AWARD

1982 Don Weaver
1983 Ken Wolvington
1984 Bill Black
1985 Fred Wuensch
1986 Eleanor Weidner
1987 Bob Newton
1988 Georgene Raub
1989 Barb Emerson
1990 Miles Weidner
1991 Linda & Nile Schneider
1992 Joe Woods
1993 Bob Newton
1994 Randy Whitney
1995 Lewis Wetzel
1996 Mark Gardner
1997 Jim Carroll
2000 Jonathon Haas
2002 Patrick Zachary
2003 Mark Gardner
2004 Marilynne Johnson
2005 Gerald Duval
2006 Jim Finch (posthumously)
2007 Jon Fick

SPORTSMANSHIP AWARD

1987 Les Chirgwin
1988 "Adrenalin": Bill Piper, Tim
McKegney, Chris Morgan, Mark
Naud & Mike Cimonetti
1989 Alex Nimick
1990 Joe Woods
1991 Mark Gardner
1992 Julie Weaver
1993 Janice Lange
1994 Andy Horton
1995 Dick Spurlock
1997 Janice Lange & Marcy Milton
2002 Al Hobart
2003 Bill Rogers
2006 Gerry Couture
2007 Gerry Couture

SEAMANSHIP AWARD

1939 Paul D. Raine
1940 W.R. Christopherson
1941 Lawrence Damon
1947 Gordon C. Morse
1949 E. Austin Biehl
1950 William W. Baldwin
1951 Ethan A. Sims
1952 Stephen Truax
1955 F. Wendell Floyd
1956 Timothy C. Davis

1957 Robert G. Sidle
1958 William Wiese
1959 David Gray
1960 David Partridge
1961 Ray Patenaude
1962 Thompson & Wright
1964 Steele T. Griswold
1967 Philip H. Davis
1970 Steele T. Griswold
1972 Alden Bryan
1975 Fred Allen
1977 Don Brush
1978 Don Brush
1979 Mark Shearer
1981 Jim Corcoran
1982 Bernie Thurber
1983 A. Johnson/D. Little/B. Newton
1986 Miles Weidner/Ken Wolvington
1988 Al Russell/Al Hobart & Crew
1989 Fritz Senftleber
1991 Ken Wolvington
1993 Randy Whitney
2001 Tod Cox
2006 Lynn Gardner / Marilynne Johnson
2007 Bombard Family

LASER AWARDS

2004 Chris Doyle
2005 Al Russell
2006 Al Russell
2007 Al Baker

MBBC WINTER REGATTA

1989 "Panache" - Jon Aswad, MBBC
1990 "Buzzard" - Bruce Nourjian, Stowe YC
1991 "Showtime" - Don O'Brien, LCYC

BEST FEMALE SAILOR

1993 Ann Brush
1994 Holly Schwartz
1995 Heather Rowe
1998 Marcy Milton
1999 Tammy Ouellette
2000 Heather Rowe, Ann Brush, Tammy
Ouellette, Kate Brush
2001 Janice Lange
2002 Kika Bronger
2003 Heather Ambrose
2004 Suzy Coburn
2005 Allyson Russell
2006 Marcy Milton
2007 Kay Tran

FINCH CUP









2007 Joan Shannon

FREEMAN AWARD

2006 John & Genie Soboslai
2007 Mark & Rita Baglini

How Does The Starting System Work?

The following table describes sequence for using the Starting System.

| Title | Visual Signal | Sound Signal | Time to Start |
|-------------|--|---|---------------|
| Warning | Class Flag(s) Displayed | 1  | 5* minutes |
| Preparatory |      Blue with a white square Yellow with a black dot Yellow Black Blue Red Yellow Black Blue Red Black Flag | 1  | 4 minutes |
| | Preparatory Flag(s) Removed | 1  | 1 minute |
| Start | Starting Class Flag Removed New Starting Class Flag Raised | 1  | 0 |

* or as stated in the sailing instructions
 The warning signal for each succeeding class shall be made with or after the starting signal of the preceding class.

The Midweek and Fall Series

The Midweek and Fall Series, have multiple starts. The starting sequence is uninterrupted. The starting signal for the starting class is the warning signal for the next class. If the start is fair, meaning no one was on the course side of the starting line at the start, the next class flag is raised as the starting class flag is lowered. (one up and one down)

Individual Recalls:

In the case of an Individual Recall, after the next class flag is raised, one additional sound and the Individual Recall Flag will be raised. The Race Committee will attempt to hail the guilty boat(s), although it is the boats responsibility to start properly. The Race Committee attempt to hail them is a courtesy.

General Recalls:

In the case of a General Recall, after the next class flag is raised, two additional sounds and the General Recall flag will be raised. In the event of a General Recall the recalled fleet will start at the end of the class starts.

Starts with only one Sequence:

The starting sequence follows the Racing Rules of Sailing "26 Starting Races" as detailed in the graphic above.

